

EMPTY WEIGHT 55 LB.  
GROSS WEIGHT 255 LB.

# BUILDING THE ICARUS II

BY TARAS KICENIUK JR.

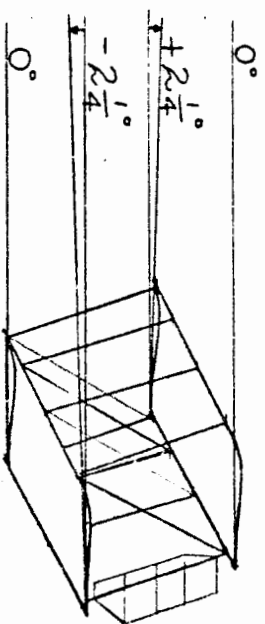

## PREFACE

The biggest news in aviation today is not the supersonic transport, the variable geometry fighter, or the super-jumbo cargo plane. On the contrary, man's greatest leap forward looks at first glance like a giant step backward!

A growing awareness of man's overdependence on super-technology and of his pollution of an overcrowded world has made him look back and examine the alternative paths bypassed or overlooked in the search for more speed, complexity, and commercial return. One modern disappointment has been in the area of private flying, where airplane manufacturers vie with each other to produce a flying vehicle most like its Detroit-built cousin clogging the freeways below. Airports have given way to housing tracts, and those that remain offer traffic control and exorbitant monthly fees for the privilege of tying the aircraft down in the great outdoors.

But soaring is different - or is it? Soaring sites are even more scarce and remote than are airports, and direct flying costs can equal or surpass those of power flying. Then there is the dependence on a host of helpers, tow pilots, retrievers, etc. Nothing shatters the perfect picture of sailplanes spiralling in the clouds overhead as does the never-ending din of towplanes taxiing, running up, and taking off.

Reawaken the childhood dream of effortless, silent, flight! A small group of romantic enthusiasts took a second look at the essential elements of man flight and came up with a startling discovery. Man need not accept all of the shortcomings of present day aviation to enjoy the miracle of flight. And so there was born a motley flock of almost-aircraft which skimmed through the air a few feet above grass-covered hillsides.

It was at this point in time that my sixteen year old son, Taras, and his buddies chipped in to buy a scanty set of "plans" for building a polyethylene covered Rogallo-type hang glider out of bamboo. Although

putting in a creditable show at a local meet, it was obvious that greater performance, controllability, and easier ground handling were much to be desired.

Watching the many ludicrous "flights" of the Chanute-type replicas, and the expert performance of Richard Miller in his flying wing, I offered the gratuitous observation that "the ideal hang-glider would be a swept-wing tailless biplane with a reflex-cambered airfoil."

I guess young Taras thought so, too, because the next day found him making a four-foot span flying model piloted by an articulated toy doll for boys (yes!) called G. I. Joe. The business-like way in which he tackled the problem of aerodynamics and structural design and research augered well for the project which came to fruition in the ICARUS - and which made an appropriately fitting debut at the J. J. Montgomery Memorial near San Diego. The ease with which ICARUS outdistanced and outclassed the other entrants led several bystanders and participants to enquire if they might purchase a set of the plans. Well, no plans existed - the aircraft having grown from rough sketches and back-of-the-envelope calculations. Realizing that other enthusiasts might learn from his experiences, Taras wrote up the narrative which described the building and flying of ICARUS.

After several flights of five minutes duration, terminated at the discretion of the pilot, in which Taras soared higher than the take-off point, it became obvious that ICARUS was something of a Frankenstein's Monster. The original "sky-surfer" began to look more like a new breed of ultra-light, self (foot) launched sailplane which could open the door to soaring sport for many and in places only dreamed of before. Ideas for an ICARUS II began to take shape in which structural refinements would be incorporated - and just in time.

A novice would-be bird man contributed his services as a test pilot by subjecting ICARUS to severe aerodynamic loads while a few feet above the ground. The result was first a pair of buckled diagonal struts, followed immediately by the collapse of much of the rest of the craft. An ideal time to begin ICARUS II!

Aerodynamically identical to its predecessor, number two shows the same performance, and the same excellent control characteristics. Polyethylene covering has given way to aircraft Dacron and details of the center section and control systems have been changed for greater convenience and reliability. Sporting FAA registration numbers on its wing tip rudders, ICARUS II flies in ways and places formerly reserved only for hawks and seagulls.

Taras Kiceniuk

December 1971

## INTRODUCTION

This book was written in order to document my experiences so that others might benefit from them and discover the thrill of true bird-like flight.

ICARUS II was built after the demise of ICARUS I and incorporated the lessons that were learned from ICARUS I. Some changes that were not really necessary were also included in ICARUS II (mostly for convenience or for esthetic reasons) and in these instances the techniques used in ICARUS I have also been retained in the text as possible alternatives.

In order to place ICARUS in its proper perspective it would be helpful to look at the various classes of manned, fuel-less flight as proposed by the Self Launch Flight Group (SELF-G), a new organization that hopes to foster and coordinate the "Ultralight" movement.

Class 0 - Tethered flight

Class I - Ground Skimming - Flights within a few feet of the ground where little or no control is required.

Class II - Flight within several wing spans of the ground where pilot error or structural deterioration (short of total collapse) would not be serious. The craft would, however, be under positive control whether by weight shifting, aerodynamic surfaces, or both.

Class III - Controlled Soaring Flight - Craft must be under complete control and pilot discomfort or structural deterioration must not limit flight duration. Ridge and dynamic soaring at altitudes less than 100 feet would fall under this category.

Class IV - Unlimited soaring flight in places and at times conventional sailplanes usually fly, excepting that the launch would be non-mechanical. Aircraft in this class would definitely require FAA inspection and licensing.

The FAA's position on the ultralight glider is still uncertain and undefined. I have heard that the distinction between aircraft and "toy" was made at the introduction of controls, but this is rather vague and will depend on the local FAA office.

ICARUS II was inspected and licensed by the FAA and I strongly urge anyone else building an ultralight for anything more than Class II flight to do likewise. It was a simple operation and cost only \$5.00. One should contact his local office a week or so prior to covering the craft.

To date ICARUS has been operated as a Class III machine and no "bugs" have been uncovered since the strut failure on ICARUS I, but there has not been enough flight experience in ICARUS or in any of the ultralights in general to know the aerodynamic and structural limits of flight. For this reason, the drawings and instructions contained in this book do not express or imply that aircraft built in accordance with them meet any set standards of airworthiness or structural integrity.

## CHAPTER I

### AERODYNAMIC DESIGN

The design goal for ICARUS was good performance, high lateral and longitudinal stability, and low directional stability. Simply stated this means that ICARUS should want to keep its wings level, and to maintain a fixed speed and angle of flight - but not care much whether it points in the same direction it is flying, or flies in the direction it is pointing. These qualities are insured by the following design features:

#### I. Longitudinal Stability

(A) Wings are swept backward with tips twisted about  $2-1/2^{\circ}$  downward.

(B) Airfoil has "S" shape which insures small center of pressure travel.

(C) Upper wing is forward of, and at positive angle to, lower wing (positive stagger and decallage).

(D) Low center of gravity of pilot and craft.

#### II. Lateral Stability

(A) Wings are set at generous dihedral angle (2-foot rise in  $14-3/4$  foot semi-span).

(B) Wings are swept.

(C) Low center of gravity of pilot and craft.

#### III. Directional Stability (Low)

(A) Absence of fixed vertical stabilizer.

The desirability of possessing these qualities will not be discussed at length, but the reader is encouraged to consider the characteristics of those ultralights that do not have them. It is a biplane because only that configuration lends itself to the strength and rigidity desired in a machine which may encounter strong gusts in flight, must be very light, and which may make a large percentage of its landings in tall grass or uncertain terrain.

(cont of Chapter One)

The aerodynamic performance might be enhanced by carefully modifying some of the aforementioned stability features, and systematic experimentation by experts is very desirable. On the other hand, it is a program that must be undertaken with extreme caution since nasty flight characteristics may result, and these may not be apparent under normal flight conditions.

Speaking of performance improvement, streamlining the wing struts and fittings should produce significant results with no sacrifice in handling or safety.



CHAPTER II  
STRUCTURAL DESIGN

The structural design of ICARUS II was based on an assumed pilot weight of 200 lbs. The following summary gives the approximate force in the structural member listed at normal flying speed, assuming a 200 lb. pilot.

I. Upper Wing Leading Edge Tube:

This member is in combined compression and bending. The "bays" have been made increasingly larger to equalize their susceptibility to column buckling, thereby making more economical use of the constant diameter tubing. Maximum compressive force carried by this member in the inboard bay is approximately 135 lbs. This is the most highly loaded element in ICARUS:

For a 200 lb. pilot at 1 g:

Innermost Bay	135 lbs.	compression plus bending due to distributed lift
Middle Bay	85 lbs.	" " " " " " "
Outboard Bay	30 lbs.	" " " " " " "

II. Upper Wing Trailing Edge Tube:

Innermost Bay	60 lbs.	compression plus bending due to distributed lift
Middle Bay	40 lbs.	" " " " " " "
Outboard Bay	15 lbs.	" " " " " " "

Note - All compression members are subject to collapse by buckling if bent or kinked. If compression members are accidentally damaged, they must be repaired before flight.

III. Lower Wing Leading Edge Tube:

Innermost Bay	60 lbs.	tension plus bending due to distributed lift
Middle Bay	30 lbs.	" " " " " " "
Outboard Bay	0 lbs.	" " " " " " "

## IV. Lower Wing Trailing Edge Tube:

Innermost Bay	25 lbs. tension plus bending due to distributed lift
Middle Bay	15 lbs. " " " " " " "
Outboard Bay	0 lbs. " " " " " " "

## V. Struts:

Most struts are in compression. Numbering the struts 1 through 4, starting with the Inboard Strut, and with F meaning Forward, D Diagonal, and R Rear, the following table lists the compressive load:

	1	2	3	4
F	Tension	55 lbs.	33 lbs.	12 lbs.
D	65 lbs.	4 lbs.	7 lbs.	5 lbs.
R	Tension	22 lbs.	15 lbs.	5 lbs.

Notice that the inboard diagonal strut is the most highly stressed.

VI. In normal flight, all cables directed upward and outward take the flight load, those going downward and outward are very lightly loaded. Starting inboard, the flight cables are loaded in tension approximately as follows:

	1	2	3
F	85 lbs.	75 lbs.	35 lbs.
R	35 lbs.	30 lbs.	18 lbs.

The strength of the wire should be at least 4-1/2 times these values to withstand flight loads of 3g with a safety factor of 1-1/2. These loads have been presented to draw attention to those members which are highly loaded, and those which are not, in the event that local material availability requires a change in component dimensions.

A simple test of the completed craft can be performed in the field which will tell if the structure will withstand, say twice the normal straight-ahead flying loads. It will be noticed that ICARUS (with pilot aboard) nearly balances at the lower end of the middle outer strut (No. 3F above). As a first approximation it can be assumed that all of the lift on each side is concentrated at this point, so if several men grab the

lower wing spar a few inches on either side of this strut they can support the aircraft-plus-pilot in level flying position. A couple of men (or women) can support the rear spar in similar fashion just to keep the craft level in the fore-and-aft direction. If everything goes well with one person hanging from the hang tubes, another person can join him, thus testing the basic structure for two "g's". The craft must then be inspected to be certain the cables, fittings, etc., have not failed.

CHAPTER III  
CONSTRUCTION

Ribs:

1. The plans were laid out and a template made from a piece of masonite. This was done by laying out plates no. 3, 4, 5, 6, gluing them to the masonite with Scotch Spray adhesive and cutting along the inner line with a jig saw.
2. Nine 40" x 1/2" x 12" pieces of foam were bought from a florist supply house. Actually I found it necessary to do some splicing as the foam was available only in 36" lengths. (Weldwood water mix glue was used to make the splice.)
3. Two sheets of foam were stuck together with pins and toothpicks and the template was pinned securely on top of the foam. Using the template as a guide the styrofoam was cut with a hot wire saw, making two ribs at a time. (A hot wire saw consists of a piece of steel or nichrome wire under tension and wired across the secondary winding of a filament transformer.) Altogether 26 ribs were cut out in this manner.
4. Fifty-two 1/8" x 1/2" x 42" straight-grained spruce sticks were cut up on a circular saw into cap strips, and sanded smooth.
5. The cap strips were glued to the top and bottoms of the ribs using plenty of the weldwood glue. The strips were held tight against the foam while the glue dried with string and rubber bands. It was also necessary to put the ribs in a jig while they dried to keep the cap strips from deforming the foam (see plate no. 4).
6. The ends of the ribs were sandwiched between two pieces of 1/32" plywood as is shown on the drawing. Note the way the

pieces were staggered to account for the sweep back of the wing. Great care was taken to make 13 left hand ribs and 13 right hand ones.

Important: The plywood was glued so as to make the rib 1/4" too long (1/8" front and rear), then sanded to the final correct length just prior to assembly. In this way it was possible to make the ribs fit the spars perfectly. Just before the ribs were mounted in place the wood was given a coat of spar varnish. Note that lacquer, dope, and many solvents dissolve styrofoam instantly - I always tried a sample before going ahead with a new product.

#### Spars:

1. Since aluminum tube usually comes in 12' lengths, the spars had to be spliced to 15 feet. This was done by riveting a 6" long piece of 15/16" diameter tube inside ends of the two pieces to be spliced (see plate no. 1 for location).

#### Wing Tips:

1. These are pieces of 7/8" x .030" wall, 3003 H14 tubing bent to the mean line of the airfoil. The mean line is half way between the upper and lower surfaces. The tubes were filled with sand before bending to prevent buckling. The ends were cut on an angle and filed concave to fit nicely against the spar. Two right hand and two left hand wing tips were fabricated. Angle templates made from cardboard helped in positioning wing tips in relation to the spars.

#### Wing Roots:

1. These are pieces of 1" x .016" wall tube bent to the top surface of the airfoil and are attached above the straight piece after it is in place.

#### Gussets:

1. The gussets were cut from the aluminum sheet, and bent at this time. The number and shape is indicated on plates no. 7 and 8. A broom stick or dowel of 15/16" diameter provided a convenient form for bending the gussets.

#### Controls:

1. The various control components were constructed when needed as indicated on plates no. 15 and 16. Note: The rudders were covered with the same material and in the same manner as the wings.

#### Hang Tubes:

1. Note: Before fabricating the hang tubes it was necessary to consider the control system requirements because the twist grips had to be slipped on before the hang tube ends were shaped to fit the spars.
2. The hang tube ends were deformed from the original circular cross section into a rectangle approximately 1" wide on the shorter leg so as to match the 1" diameter of the spars. On ICARUS I this was done using a bench vise and a block of wood as shown in "A" of plate no. 13. On ICARUS II, I used a saw horse with two blocks of wood clamped to it, as my vise was not large enough to accommodate the 2" tubes. The ends were then cut and filed to make a good fit where they attached to the spars, as seen in "B" of plate no. 13.

#### Wing Assembly:

1. A cardboard sweep-angle template like the one shown in plate no. 1 was fabricated to facilitate alignment of ribs, wing ends, etc.
2. The spars were laid out on a pair of saw horses, and held in place by temporarily clamping the wing tips and roots into position, using the template to adjust the sweep angle.

3. Holes were drilled for the pop rivets and the wing roots and tips were attached with the gussets. The gussets were bent by tapping with a small hammer so as to make them lay next to the tube. The "free" edge of the gusset was also bent so the gusset would be more rigid. Plate no. 11 shows the hang tubes made stiff in a similar fashion.
4. The positions of the ribs were then marked on the spars and the ribs attached with rib gussets, No. 4 self-tapping screws and pop rivets.
5. The diagonal drag/anti-drag brace was cut longer than indicated on the plan form since it had to be bowed slightly upward to keep it from projecting below the wing undercamber. As with the wing ends, the tube was filled with sand prior to bending. The sand was emptied, the tube cut to the correct length, the ends shaped, and the gussets riveted in place. A sharpened tube remnant was used to bore a hole in the intervening rib to permit passage of the diagonal brace-tube.
6. The other three wing panels were constructed in like fashion except that they were assembled on top of the first wing panel to insure absolute similarity of sweep angle, rib spacing, etc. (Care was taken not to make four left hand wings!)
7. The hang tubes were riveted to the spars at this time using the large gussets shown on plates No. 11 and 12. The center lines of the hang tubes were positioned so as to be 16" apart. This measurement can be varied depending on the width of the pilot's shoulders. Before the gussets were riveted in place approximately 7" was hacksawed from the end of each of the lower spars so that the spars came only 1/8" or so past the inside edge of the hang tube (see plate no. 11). Tape held things in place nicely during riveting. Important: The lower inboard strut/wire fittings must be riveted in place before the lower hang tube gussets are placed in position. The fittings are placed as close to the hang tubes as possible.

#### Strut/Wire Fittings:

1. The strut/wire fittings were cut out and bent at this time (16 left hand and 16 right hand) as shown on plate no. 9. Caution was observed because of the requirement that the strut pin hole line up after bending. For this reason, a bending jig was made using pieces of pipe (see plate no. 10). The 3/8" pipe was used for bending the .040" thick material, and the 1/2" pipe for the .025" thick material because of the difference in "spring back". Because of the combined stagger, sweep-back and dihedral angles, the correct mounting of the strut/wire fittings was difficult to visualize.
2. The spanwise positions of the fittings were determined from plate no. 2.
3. The "ears" of the fitting on the lower wing point forward and upward at an angle  $14^{\circ}$  from vertical, while those on the upper wing point down and backward at an angle of  $16^{\circ}$  from the vertical. This difference is due to the decalage of approximately 2 degrees. This was done by constructing templates out of cardboard, but they came out rather inaccurate. It probably would have been better to rivet the fittings with the struts in position just prior to attaching the wires though the fabric would get in the way.

#### Covering the Wings:

1. Two covering materials have been employed on the ICARUS design.

#### ON ICARUS I:

The wings were covered with 2 mil polyethylene plastic sheet, which was washed with detergent and water to remove the lubricant that is applied before packaging. The lubricant would have kept the tape from sticking on the plastic. Note: The plastic film stretches when hot and shrinks again when cool, so it was better to do the covering in the sun on a hot day.



2. A wing support was fabricated using a 16 foot long 2 x 4 with nails driven in to keep the trailing edge spar from being deformed by the pulling and stretching of the plastic film during covering. Plate no. 14A shows how this was done, and plate no. 14B shows the steps in applying the film in numbered sequence.
3. The 19' edge of a 8' x 19' piece of plastic was attached to the trailing edge, first having stretched it along the direction of the trailing edge spar. One-inch wide cloth adhesive tape made a convenient bonding material.
4. The leading edge was sprayed with Scotch-spray adhesive and the plastic attached, stretching it along the leading edge. The plastic was pulled in the direction of the ribs just hard enough to remove any wrinkles (Step 3 in plate No. 14B).
5. The wing was turned over and the plastic wrapped around the leading edge (Step 4). (The wing was removed from the 2 x 4 at this time.)
6. The plastic was pulled back to the trailing edge, cut, and taped down, stretching it at the ribs, along the ribs.
7. The plastic was then taped to the root and tip, stretching it taut.
8. A 1/2" wide strip of adhesive tape was then laid down on the plastic over each rib and stapled down to the cap strip approximately every 3" with a small paper stapler, and then another piece of tape was put over the staples. This was also done on the concave section of the bottom surface.
9. The insignia and name were applied using spray can enamel and a template. One brand of paint damaged the plastic, but I can't recall which.

#### ON ICARUS II:

The wings were covered with 1.8 oz. aircraft dacron glued to the spars and ribs with aircraft fabric cement, shrunk with a

hot iron, and given two light coats of dope (just enough to seal the fabric). During the shrinking and subsequent doping it was essential to put a wire from the point where the diagonal brace meets the spar to the rear end of the wing tip (see points marked X and Y on plate no. 2). The 1/16" baling wire was anchored to 1-1/4" long sheet metal screws temporarily screwed into the indicated gussets. The screw should go through the gusset on both the top and the bottom of the wing to prevent the tension from pulling the screw over. If the wire is omitted the wing spars will bend backwards because the swept wing, which is in the shape of a parallelogram, will tend to sweep even more as the fabric shrinks. A turn buckle was placed in the center of the wire so its tension could be adjusted and the spars kept straight.

Since the fabric was glued to the ribs it was necessary to staple only the concave sections of the bottom surfaces.

#### Struts:

1. The struts were cut and drilled as indicated on plate no. 13.

Note: The hole for the bolt that joined the strut to the spar fitting is not in the plane of the "N". It is out of plane by 15-1/2°, the sweep angle. Also: Recently ICARUS II has been flown with only four of the "N" struts (the inboard two and the outboard two) with no evident problems, and probably better performance because of the reduced drag.

#### Diagonal Strut Fittings:

1. The diagonal strut fittings made of .040" metal were used on the inboard struts, the lighter gage ones on the outboard struts.

#### Rigging the Wings:

1. The interplane struts and the two inboard diagonal struts were all placed in position and the No. 10 bolts slipped in their holes. (Some baling wire was used as temporary cross bracing to keep

the assembly from collapsing.) Note: The upper inboard strut/wire fittings were held temporarily in place with some tape.

2. The left and right wings were placed in correct relative position and boxes placed under the tips and along the wing so that the sweep and dihedral angles were correct, the spars were straight and the wings had the correct amount of wash out or twist ( $2-1/4^{\circ}$ ). Note: It is essential that the right and left wings are identical as to amount and distribution of twist!
3. The upper wing joining plugs were slipped in position and bolted to each other.
4. The aircraft turnbuckles and  $1/16''$  aircraft cable cross bracing was installed using Nico-Press sleeves and AN100-3 thimbles.
5. The lower wings were joined using four short pieces of  $1'' \times .028''$  wall tube and four wing joining plugs. The tubes are filed so as to fit nicely against the spars and so that two pieces joined with two wing joining plugs are just the correct length to fit between the ends of the lower spars. The pieces of tube were then riveted to the large hang tube gussets and the gussets bent (see plates no. 11 and 12). Important: The  $1/4''$  main bolt holes should both be perfectly horizontal and point towards each other. If they do, the wings will hinge in the center and make assembly much easier.
6. The eight wing plugs were drilled and bolted in place with three No. 10's for each plug (see plate no. 9). Note: The bolts on the top wing plugs also hold the upper inboard strut fittings in place.
7. The other six diagonal struts were now cut and drilled to fit. (Both sides of the craft were made symmetrical.) Note: As mentioned earlier under "Struts", four of the diagonal struts can probably be dispensed with.

## CHAPTER IV

## FLYING

I have flown many types of ultralights in the last two years and have learned many things, not without a fair number of skinned knees and sore ankles. So now I am setting down some of my hard learned lessons in hopes that they will be able to save those who hope to fly ultralights some pain and expense.

The first thing I learned is that the two hardest operations are taking off and landing. In both these instances one is not quite sure whether to handle the machine as if one were holding it on his back or as if one were flying. ICARUS, I have found, is much better than most, however, since on the ground or in the air it can be steered with the tip rudders. I have found it essential, if there is any wind at all, to keep the craft pointed directly into the wind with the tip rudders. When the wind comes from the side - even slightly - the wings try to bank (due to the dihedral) and it can be tricky to keep them from getting out of hand.

To take off I find it best not to have any "helpers" hanging on the wings, because they are in a very good position to hold back and swing the nose around uncontrollably. You find yourself "fighting" or correcting movements due not to the wind but to the actions of your helpers. Prior to take-off I stand supporting the craft with my back just under the rear spar holding my hands far forward to keep the nose down. When I am ready to go I start running as fast as I can, supporting the machine. Very soon I find that even slight air speed will support the wings and I can devote all my energy to running, with my hands still positioned far forward, holding the nose down. Running as fast as I can, I allow the wings to rise and the hang tubes to come up under my armpits; since my armpits are farther rearward than my hands the nose will rise slightly, the wings develop more lift, and the craft will lift me into the air. During the entire take-off run the rudders are used

to keep the wings level and to keep the machine pointing in the desired direction.

Once in the air flying is a simpler matter. The rudders are used to steer the craft and sliding one's weight fore and aft is used to control the pitch (the nose's position up and down) and hence the speed. It is essential during the flight to keep the craft flying sufficiently fast to keep it from "stalling". A stall occurs when the pilot (by sliding his weight too far back) causes the wing to meet the air at an excessively great angle. When this happens air can't take the curve around the top of the wing and much of the lift is lost.

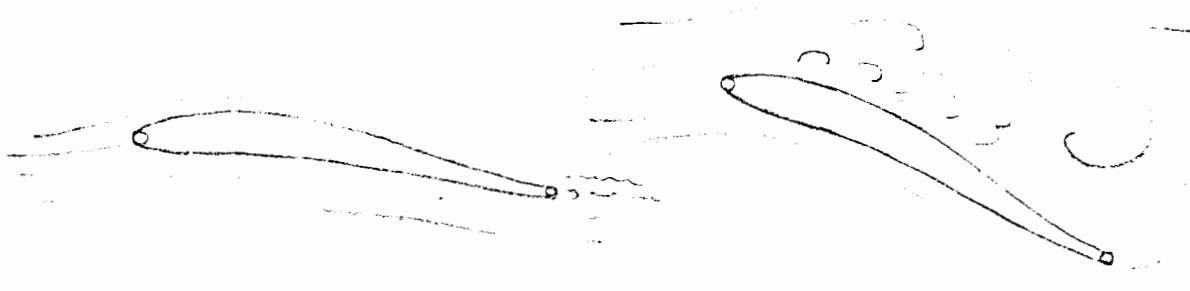

Normal (Unstalled)

Stalled

After ICARUS stalls, the craft will drop until it picks up enough speed to fly normally (where the wing meets the air at an angle of less than approximately  $15^{\circ}$ ). If the stall occurs at an altitude between 15-30 feet, the airplane will be nosing down to pick up speed just about the time the pilot hits the ground - which can be very painful to the pilot and damaging to the aircraft. So it is important not to stall when near the ground. The best way to tell how close to stalling one is would be to measure the angle at which the wing meets the air, because if the angle is small the wing cannot stall. Unfortunately, this is rather difficult to do so one is forced to use other clues as to the angle. The most valuable one of these is speed. If a wing is flying fast it need only be at a small angle to develop enough lift to keep the craft up. If it is flying slowly, however, and meeting much less air, it must push the air down at a steeper angle to get the necessary lift. So for each flying weight of the

airplane it will have one speed (in normal flight) below which it cannot fly, because at that speed the wing must assume so great an angle that it stalls itself.

An ICARUS with a 150 lb. pilot would probably stall somewhere a little below 20 mph. The air speed can be measured using a wind gauge (such as is made by Dwyer) or it can be estimated from the sound of the air rushing past all the struts and wires. The sound of "the wind in the wires" is especially useful in detecting small changes in speed. It would also be possible to measure the speed by noting one's position on the hang tubes. For at each pilot position the airplane will assume a certain angle and hence a certain speed. This also means that the ICARUS will not stall (unless hit by a sharp gust) if one is forward of a certain point on the hang tubes. This point will undoubtedly vary from craft to craft, but when it is found, a lump of tape on the tubes might well serve as a very useful reminder.

All this talk on stalls now leads directly up to the problems of landing. Just as one touches the ground it is desirable to be flying quite slowly (that is near the stall) and travelling along almost parallel to the ground (which means approaching the ground slowly). Yet when one is coming in for a landing it is important to be flying fairly fast (far from the stall) so that the tricky winds near the ground will not suddenly stall the wings. Also, as one approaches the ground the wind tends to decrease and whereas one had a nice wind of 15 mph at 30 feet the wind may only be 5 mph at 10 feet. So at 30 feet one need be flying only 10 mph with respect to the ground to have an air speed of 25 mph, which is great except that when one gets to 10 feet where the wind is only 5 mph the air speed will be 15 mph, which is less than the stall speed and the plane will drop. For these reasons it is desirable to come in for a landing fairly fast, then when near the ground (5 feet or so) to start sliding back slowly so that the craft flies along the ground slowly losing speed until the pilot feels he is going slow enough, touches his feet and starts running. It is important to note that even when the pilot's feet are touching the

ground the wings are developing some lift and will help hold him up. This is especially important during the take-off run when one is running along at close to 20 mph. These are the basic things to keep in mind while flying.

Listed below are some additional Do's, Don't's, and things to watch for, I consider before flying:

Do give it all you've got when you decide to take off. One of the hardest things to do is run along when the wings will not quite support you.

Do make sure the wings are strong enough before flight. (See Chapter II for a simple test.)

Do have plenty of speed when coming in for a landing or taking off.

Do fly over smooth, soft terrain - especially when learning.

Don't fly when the wind is gusty. (Most of my bruises were received on gusty days.)

Don't fly in places where there are objects which disturb the flow of the wind and make it turbulent. (Trees are probably the worst... you can't imagine how steep the glide path can be in this situation!)

Don't leap off hills above your ability.

Watch out for: rocks, power lines, fences, turbulent winds behind objects, dings or dents in the aircraft components that could cause collapse. Don't overestimate your gliding range.

Oh yes - another valuable hint! For a very clear and simple yet accurate description of flight, get a copy of Stick and Rudder by Wolfgang Langewiesche.

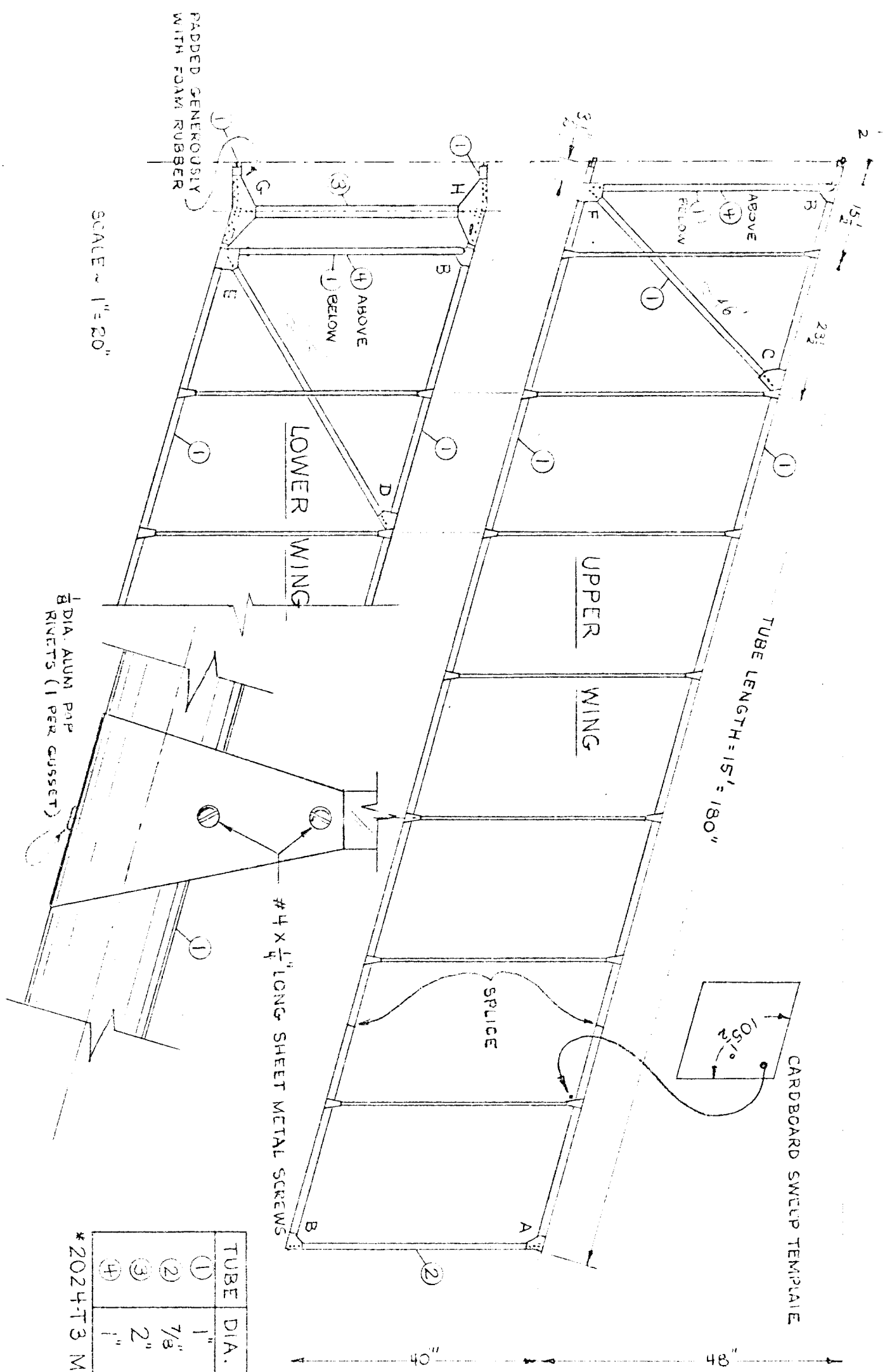

TUBE DIA.	WALL	ALLOY
① 1"	.029	606-T6*
② 7/8"	.029	3003-H14
③ 2"	.035	6061-T6*
④ 1"	.016	6061-T4

\* 2024-T3 MAY BE USED



END FITTINGS MAY HAVE UNUSED "EAR" CUT OFF

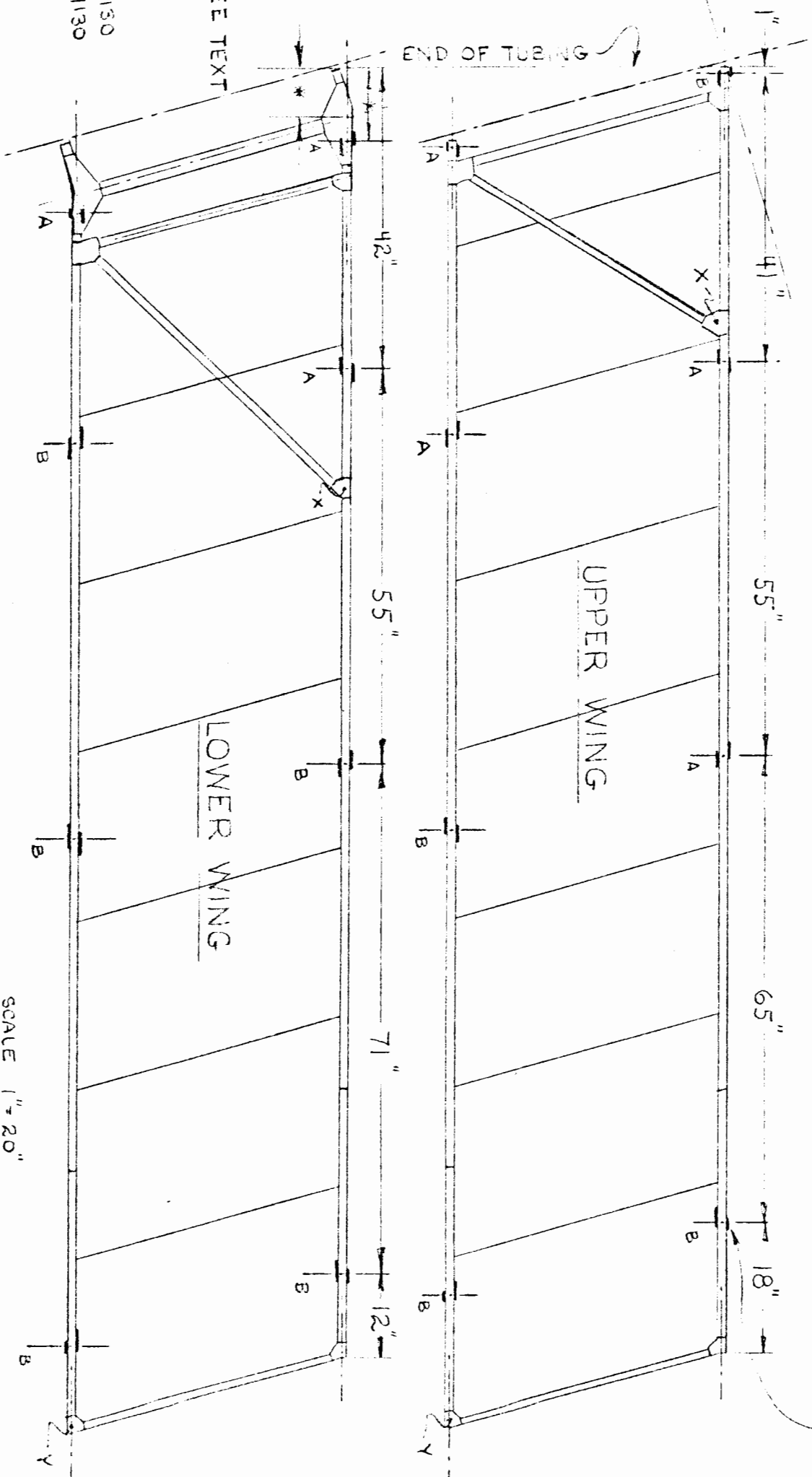

STRUT-WIRE FITTING LAYOUT DIAGRAM (TOP VIEW)

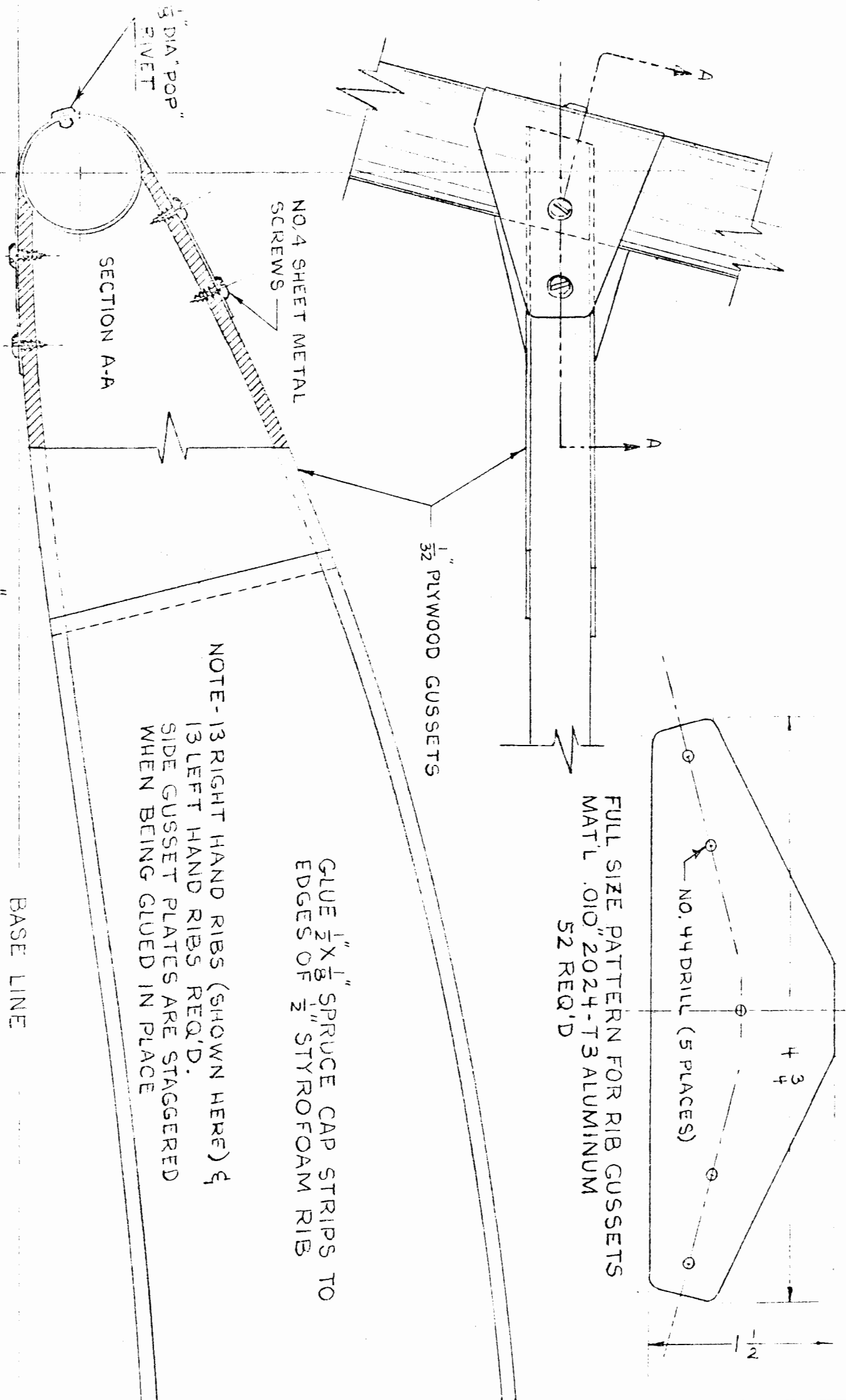

NOTE - 13 RIGHT HAND RIBS (SHOWN HERE) &  
 13 LEFT HAND RIBS REQ'D.  
 SIDE GUSSET PLATES ARE STAGGERED  
 WHEN BEING GLUED IN PLACE

GLUE  $\frac{1}{2}$ " X  $\frac{1}{8}$ " SPRUCE CAP STRIPS TO  
 EDGES OF  $\frac{1}{2}$ " STYROFOAM RIB

FULL SIZE PATTERN FOR RIB GUSSETS  
 MAT'L .010" 2024-T3 ALUMINUM  
 52 REQ'D

BASE LINE

40"

$\frac{1}{32}$ " PLYWOOD GUSSETS

NO. 4 SHEET METAL  
 SCREWS

SECTION A-A

$\frac{3}{8}$ " DIA. "POP"  
 RIVET

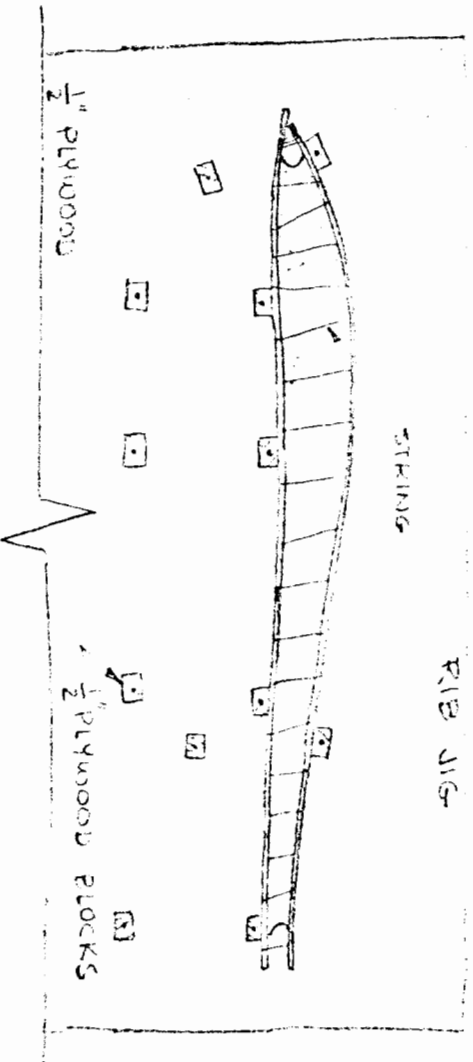

1/2" THICK SHEET STYROFOAM

BASE LINE

BASE LINE

$\frac{1}{2}$ " STYROFOAM

HANG SEAT FOR EXPERIENCED PILOT!

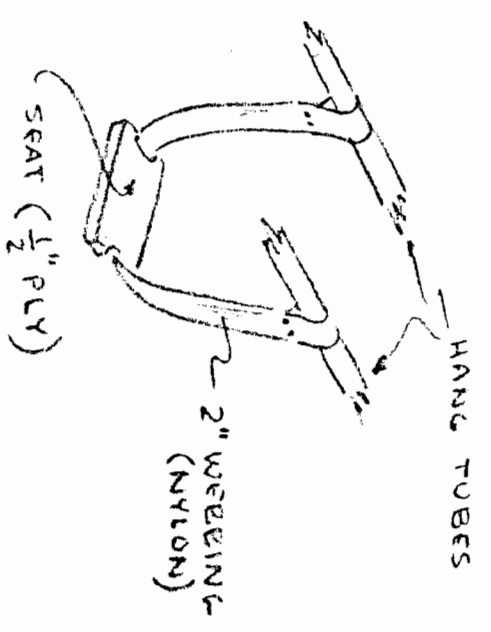

51971 TARAS

BASE LINE

40"

$\frac{1}{32}$ " PLYWOOD SIDE GUSSETS

TRAILING EDGE SPAR TUBE

NOTE STAGGER DUE TO SWEEP

$\frac{3}{16}$ "

PLATE NO. 6

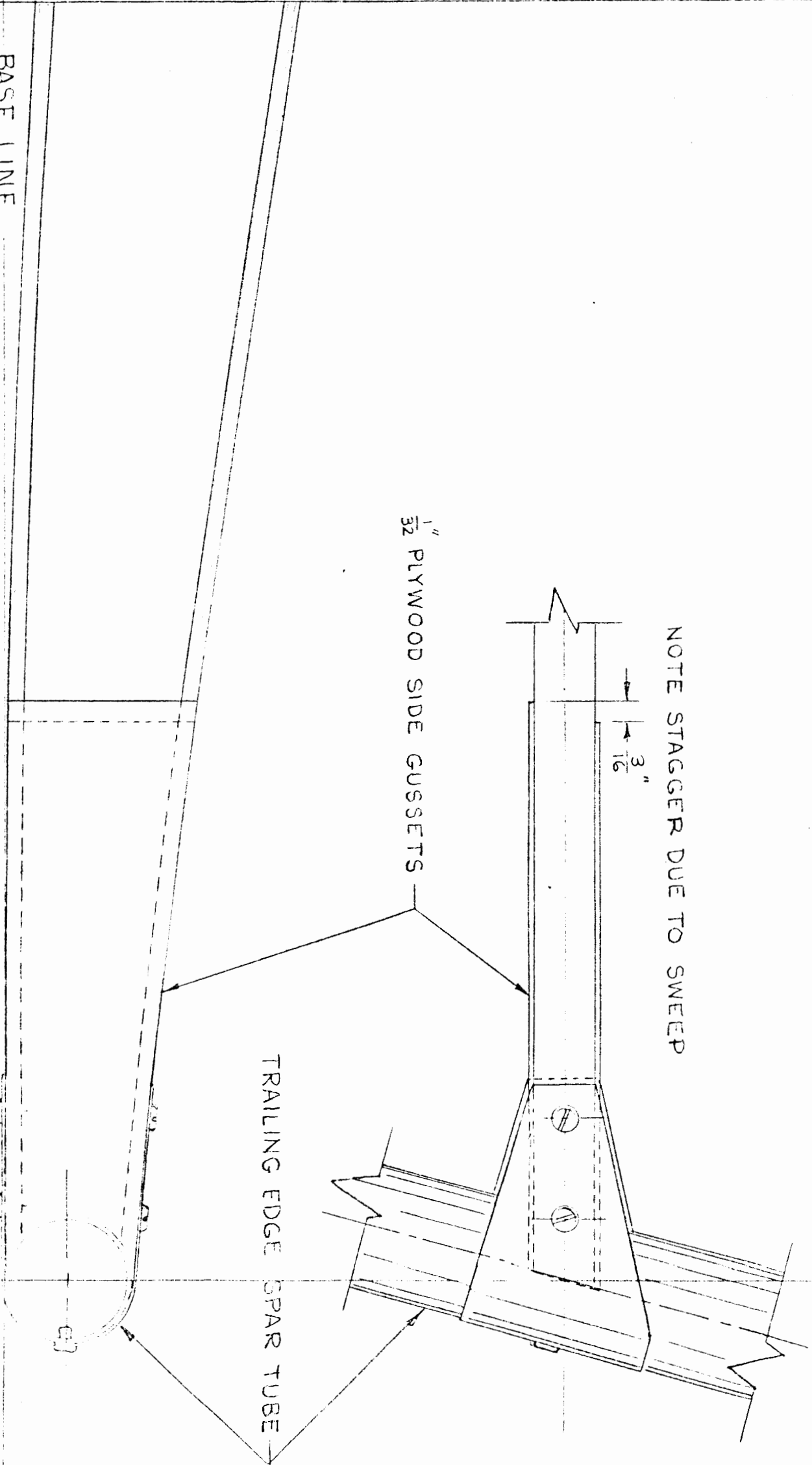

NOTE  
 CIRCLES SHOW APPROX.  
 LOCATION OF HOLES FOR  
 POP RIVETS - DRILL AT  
 ASSEMBLY

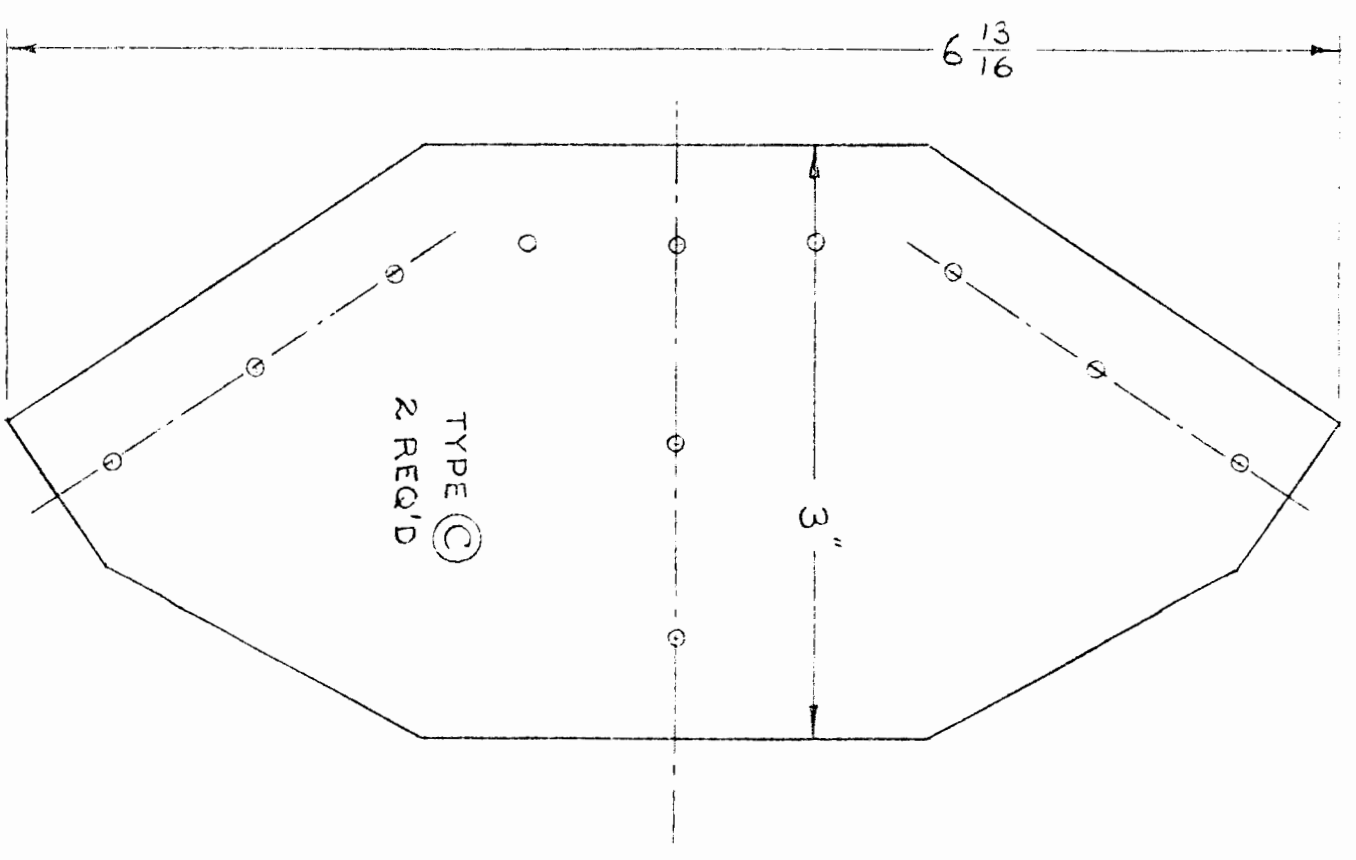
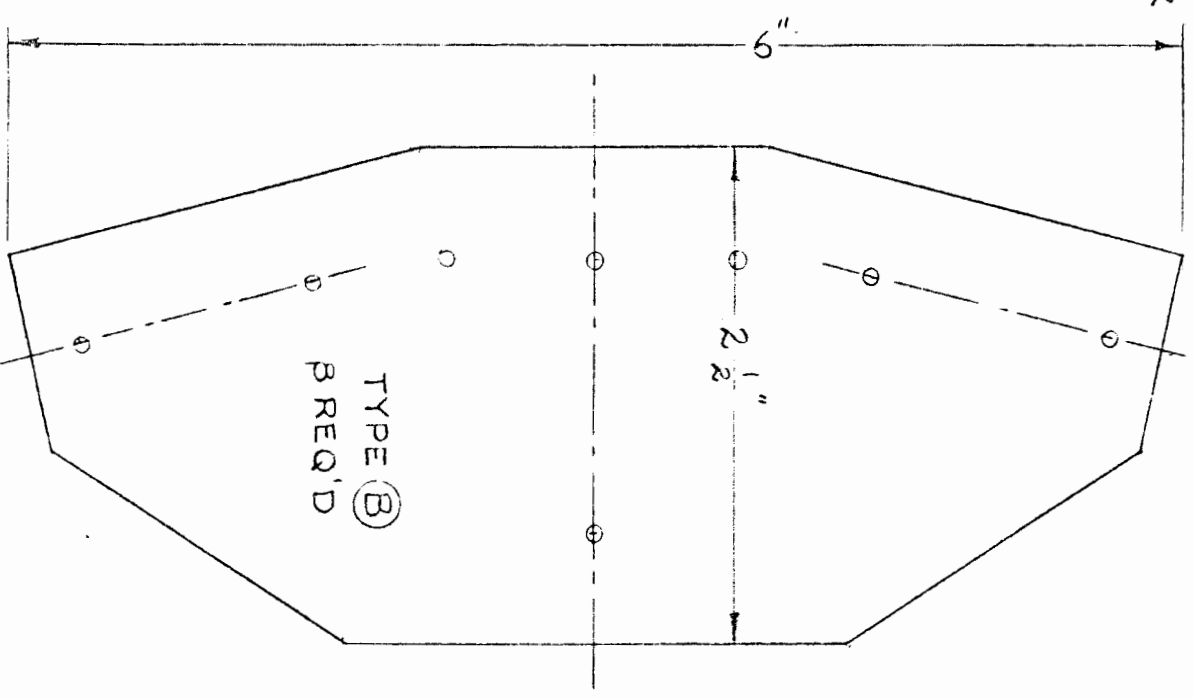
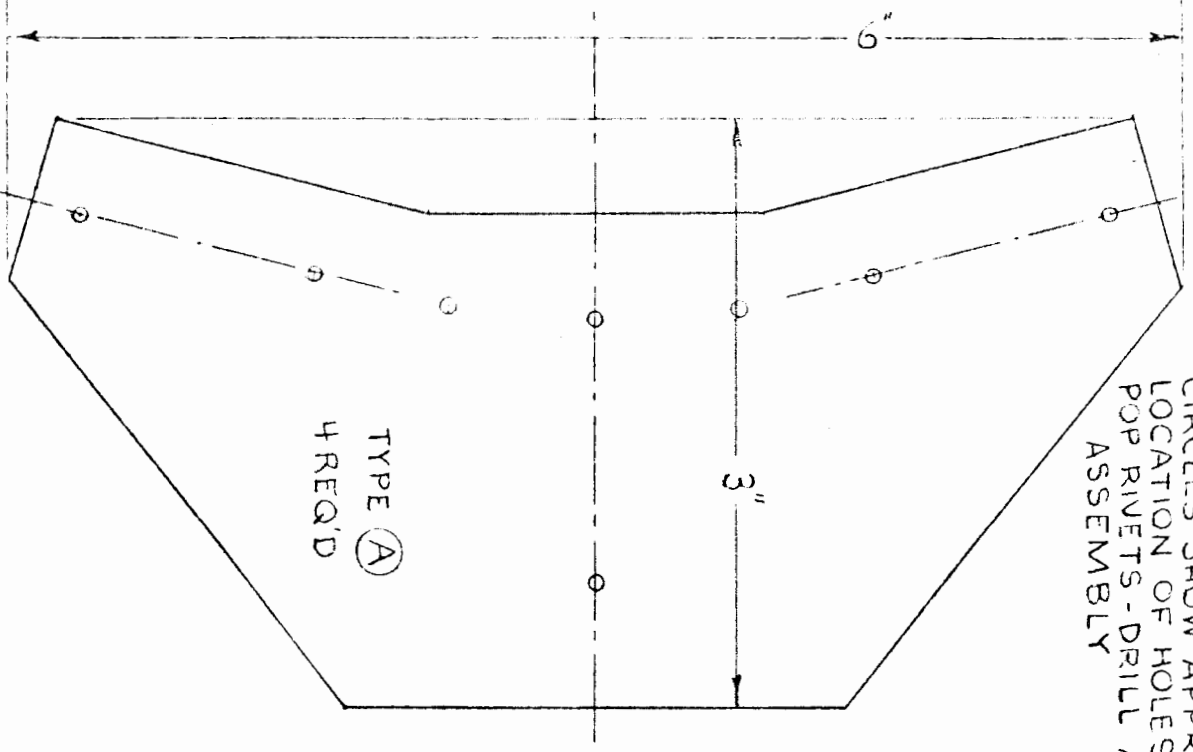

FULL-SIZE PATTERN FOR WING GUSSETS  
 MAT'L ~ .032" THICK ALUM. SHEET 2024-O  
 OR EQUIVALENT

FULL-SIZE PATTERN FOR WING GUSSETS

NOTE ~ CIRCLES SHOW APPROX. LOCATION OF HOLES FOR POP RIVETS - DRILL AT ASSEMBLY

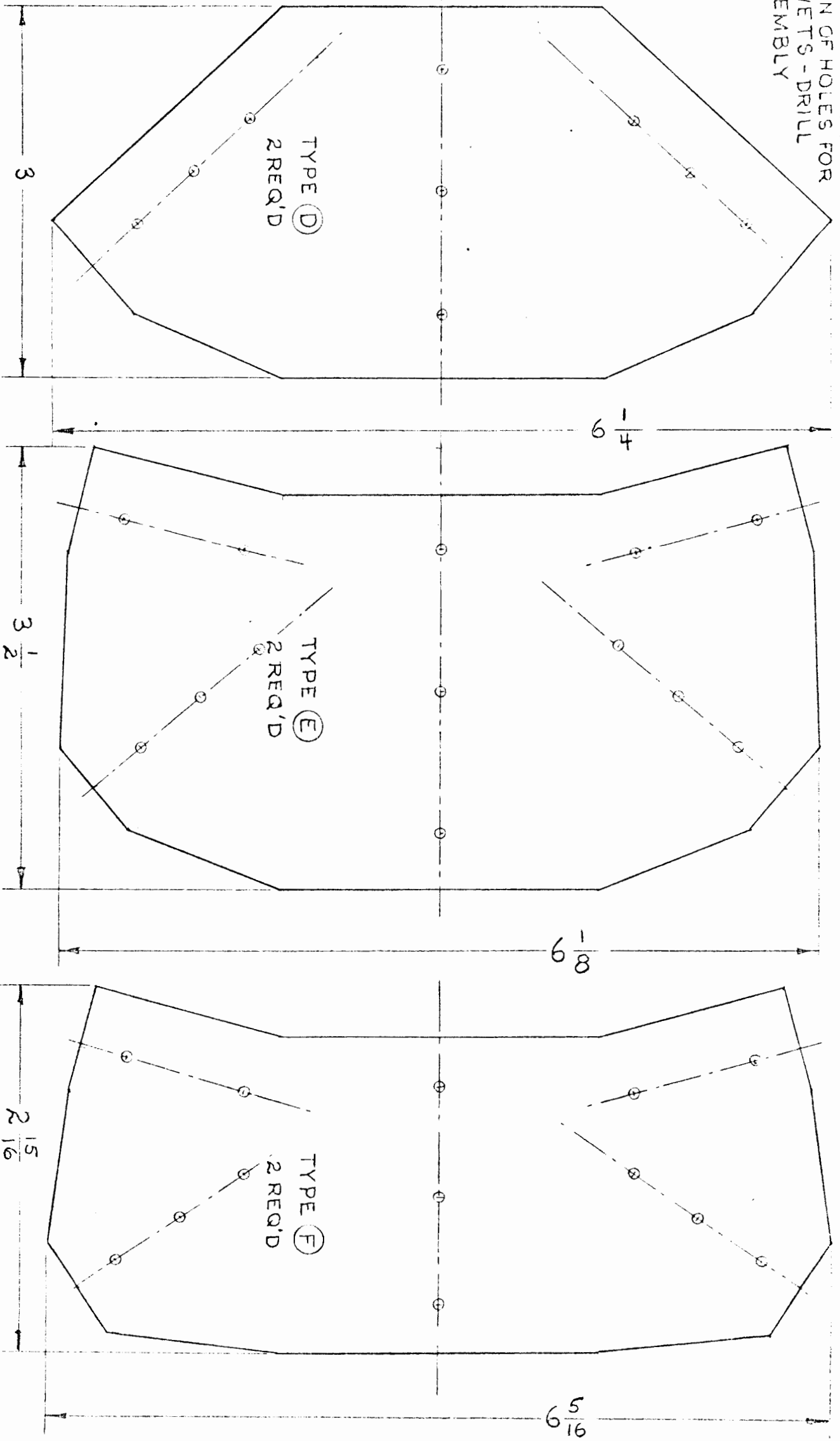

TYPE (D)  
2 REQ'D

TYPE (E)  
2 REQ'D

TYPE (F)  
2 REQ'D

3

3 1/2

2 15/16

6 1/8

6 1/8

6 5/16

01971 TARAS

MAT'L ~ .032" THICK ALUM. SHEET 2024-O OR EQUIV.

PLATE NO. 3

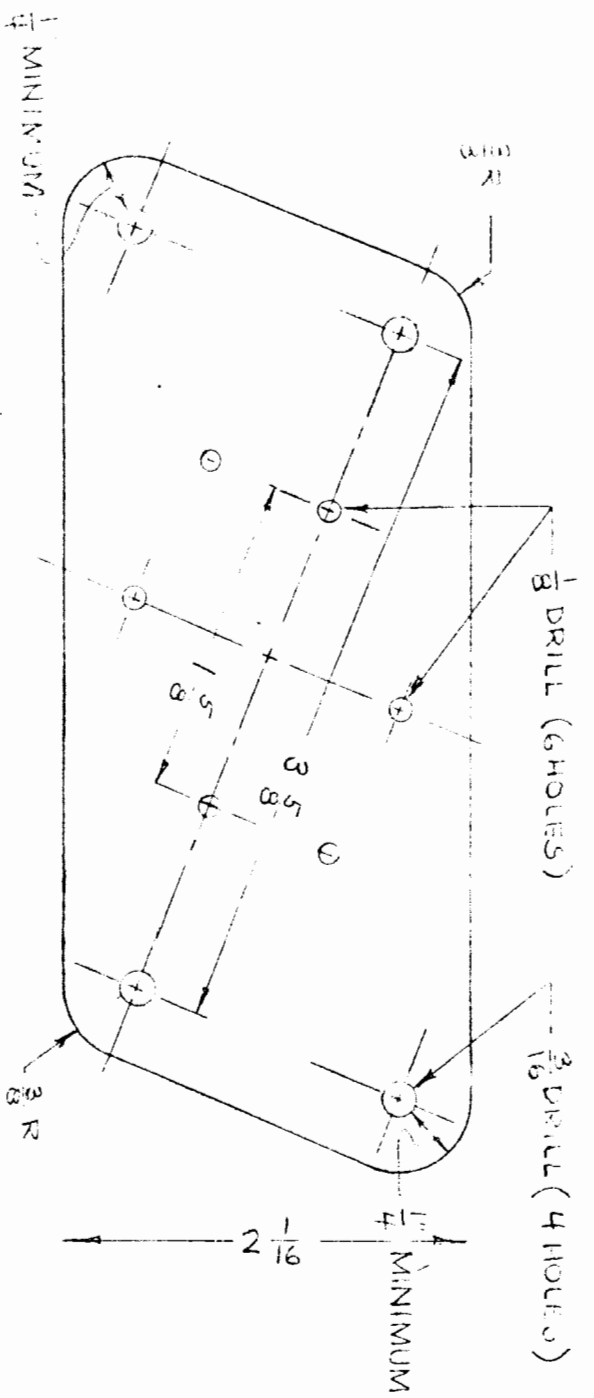

STRUT/LIFT WIRE FITTING  
 32 REQ'D ~ 4130 STEEL 5/16" DIA. .025" THICK

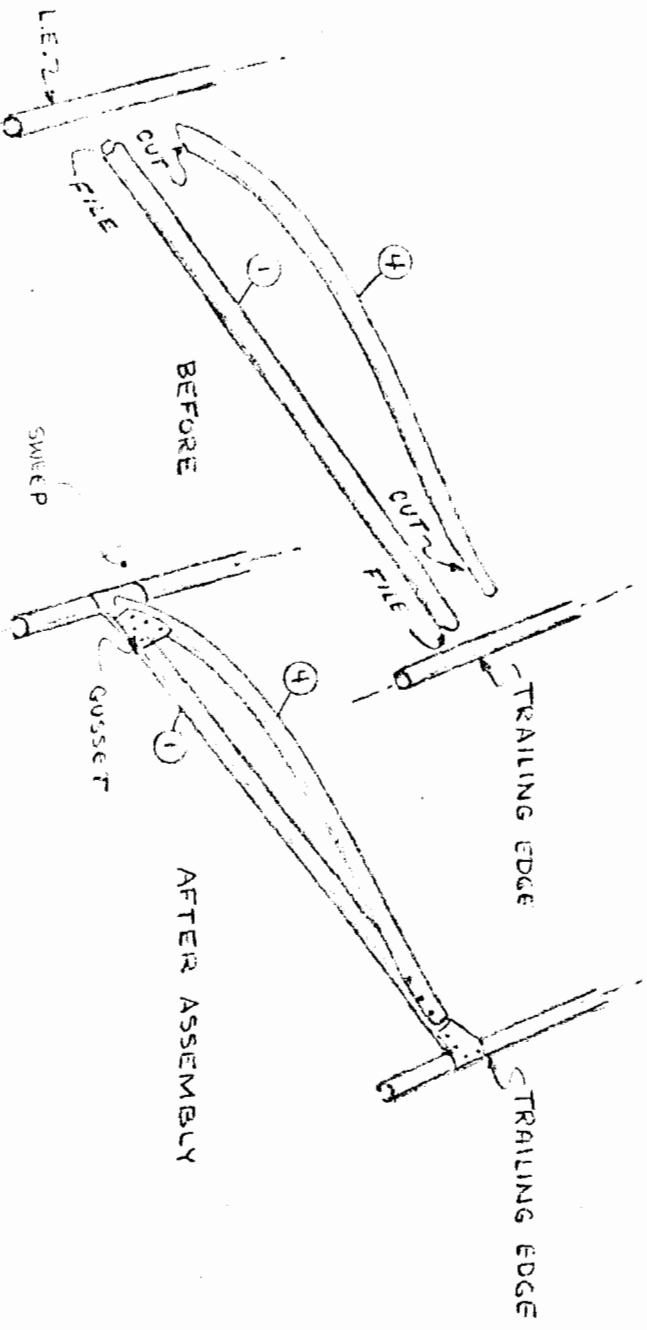

UPPER WING COMPRESSION RIB

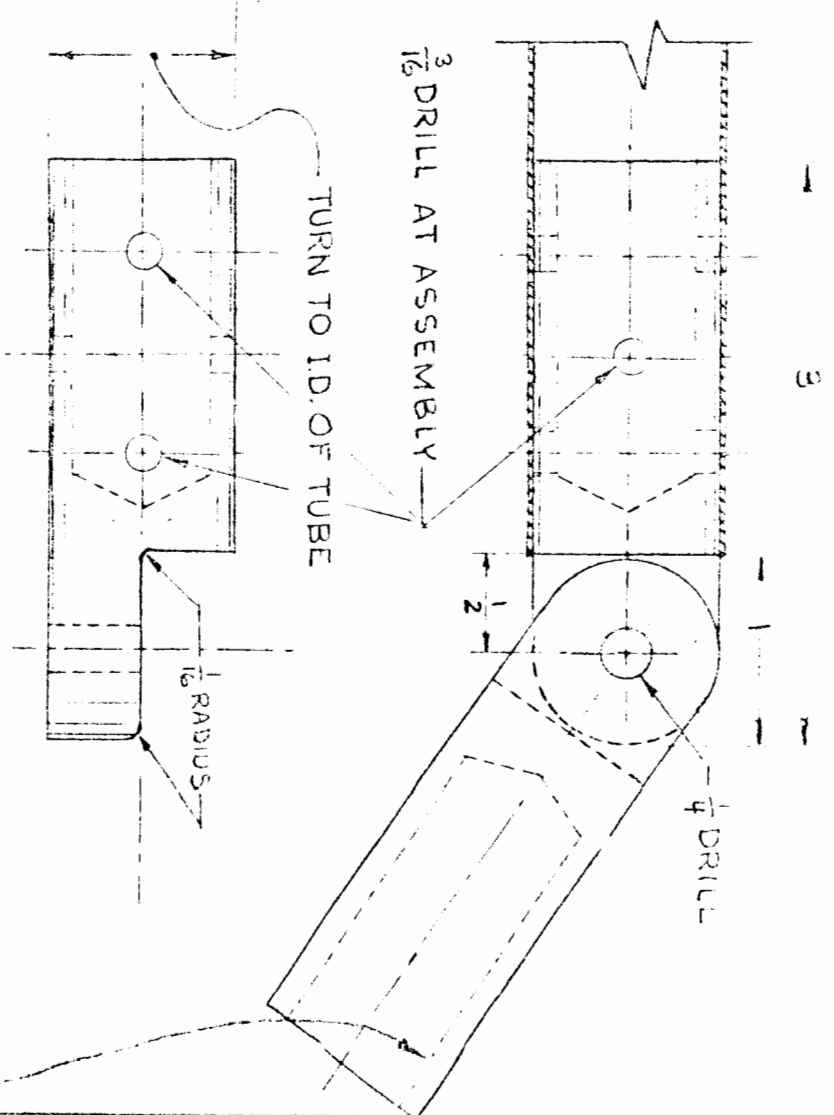

WING CONNECTOR - 8 HALVES REQ'D  
 1" DIA. STOCK - 2024-T4 OR T351  
 NOTE - WEIGHT CAN BE SAVED BY DRILLING OUT  
 FITTINGS FROM REAR. LEAVE 1/8" WALL,  
 (11/16" DIA. X 1 3/4" DEEP. DRILL)



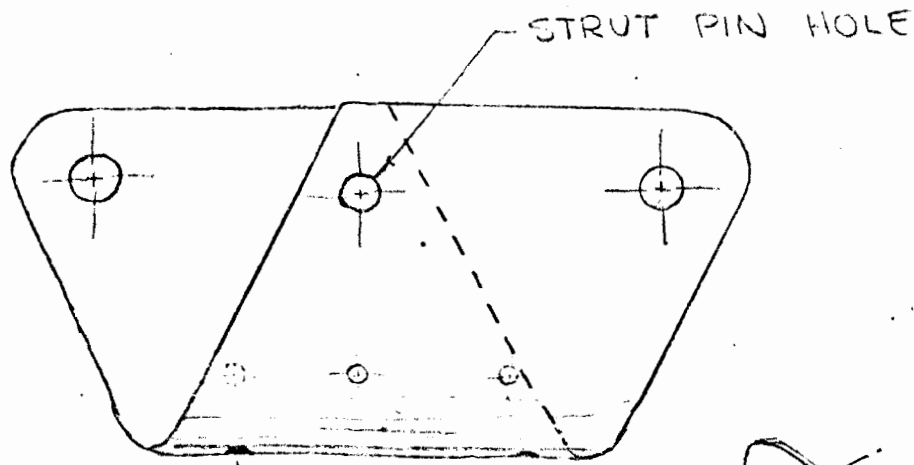

STRUT/WIRE FITTING

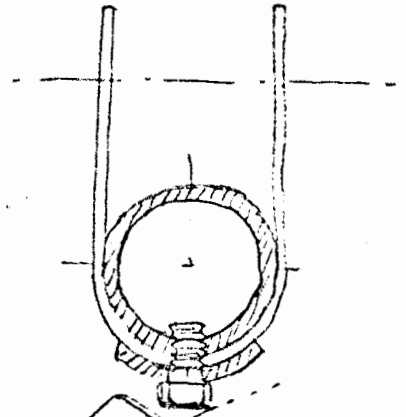

$\frac{1}{2}$ " &  $\frac{3}{8}$ "  
 NOMINAL PIPE  
 SIZE - NOT ACTUAL  
 OUTSIDE DIAMETER!

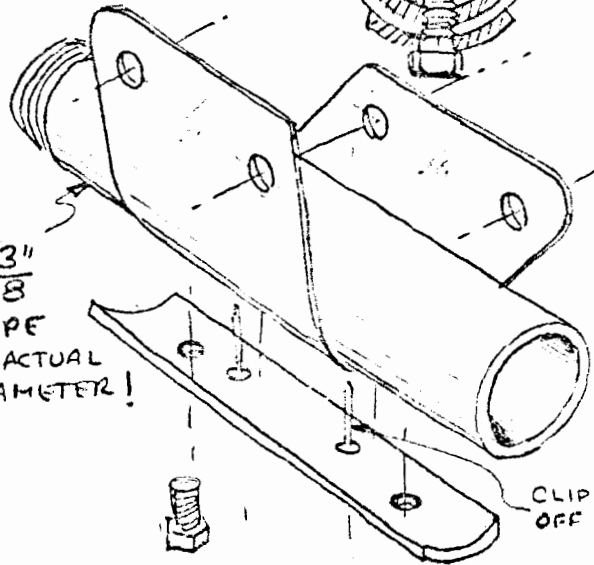

BENDING JIG

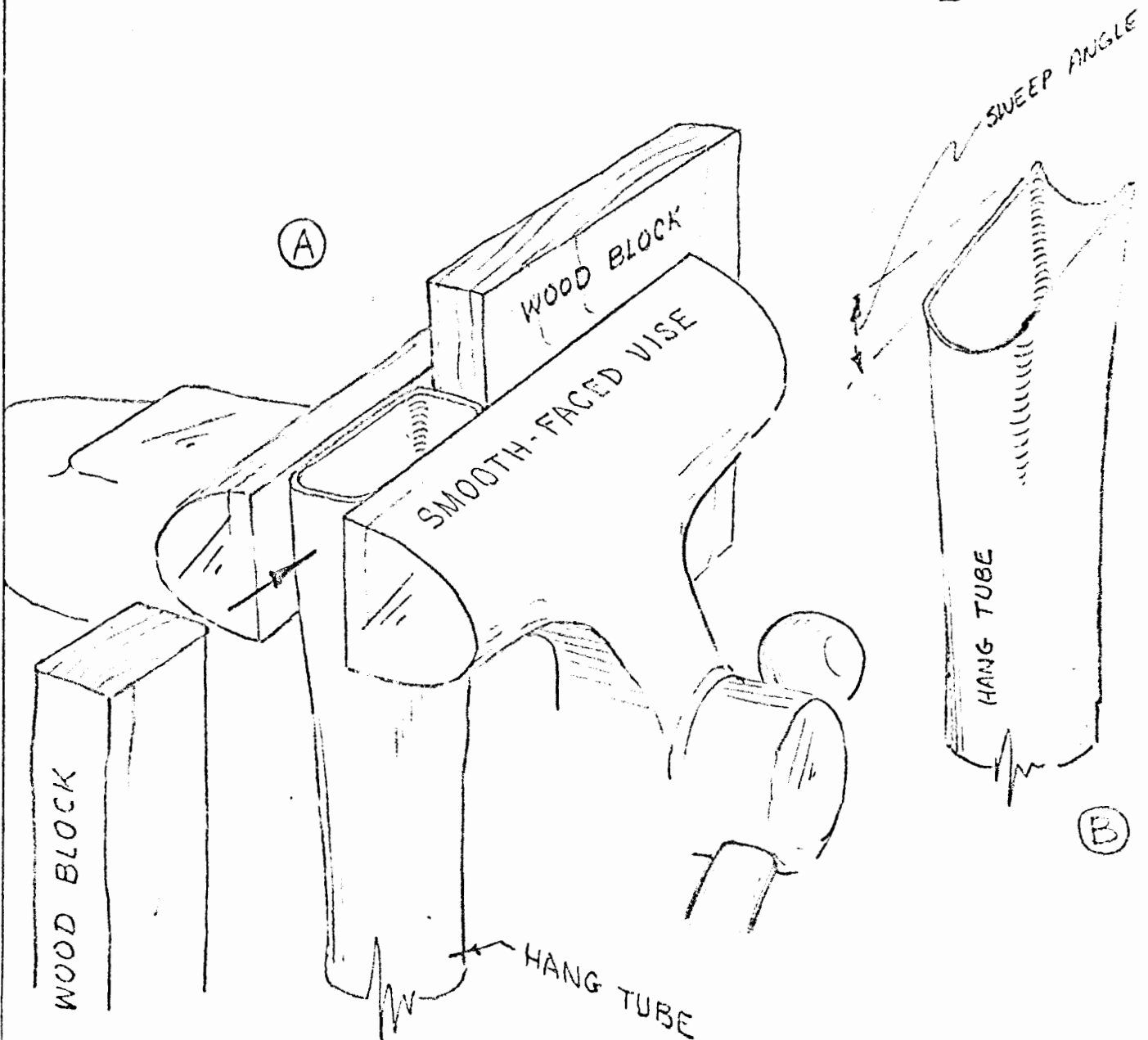

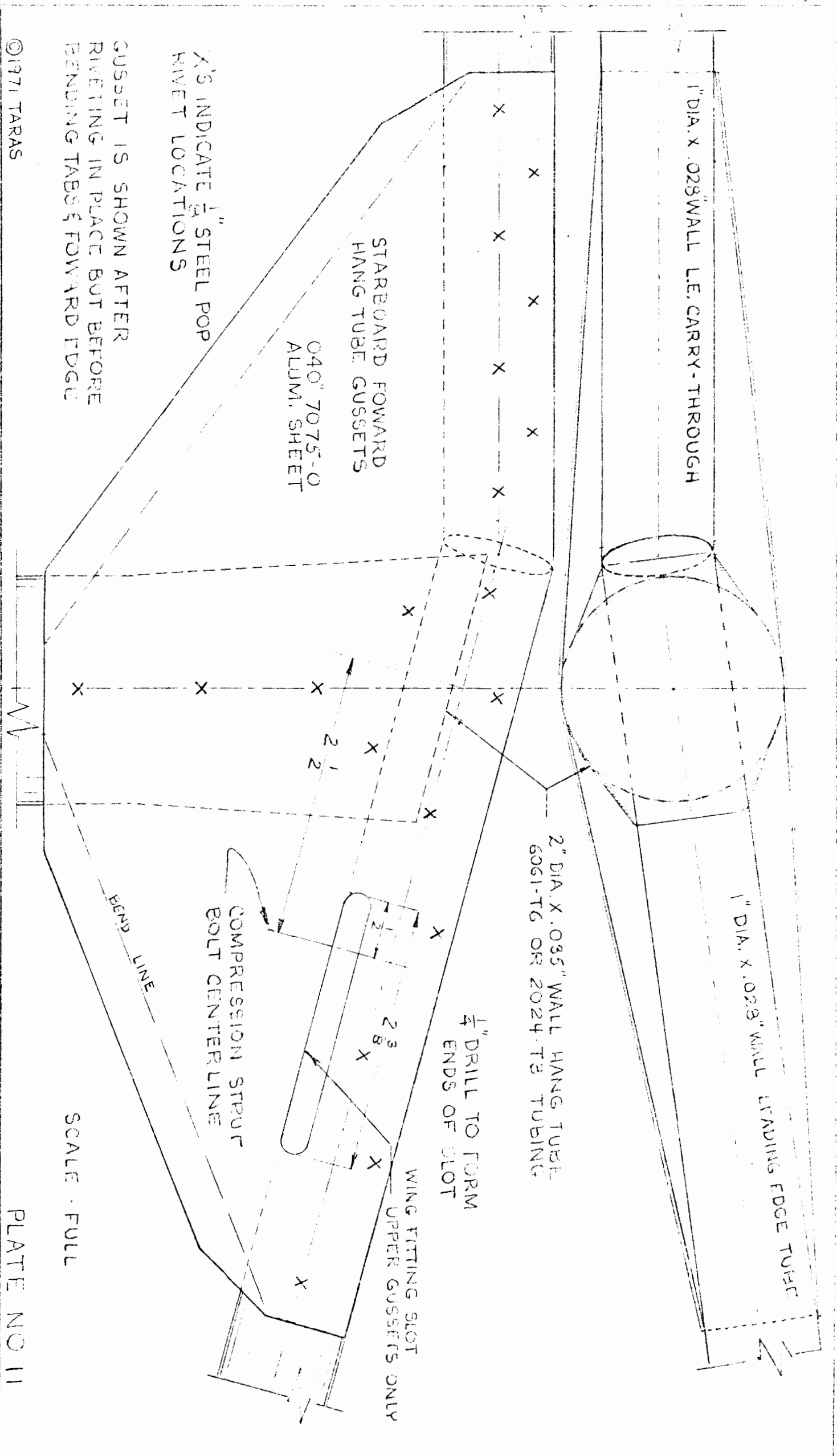

©1971 TARAS

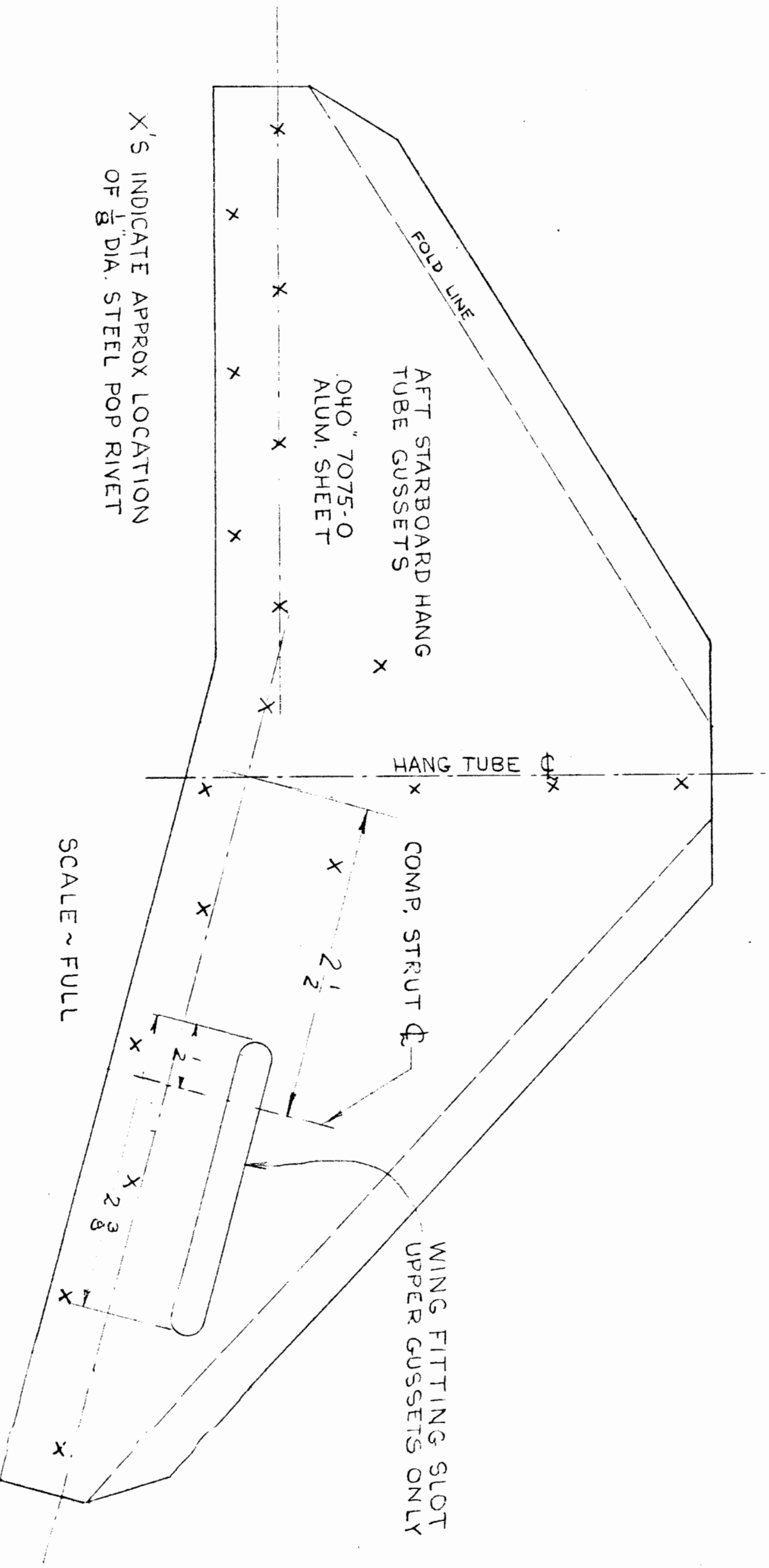

X'S INDICATE APPROX LOCATION  
OF 1/8" DIA. STEEL POP RIVET

SCALE ~ FULL

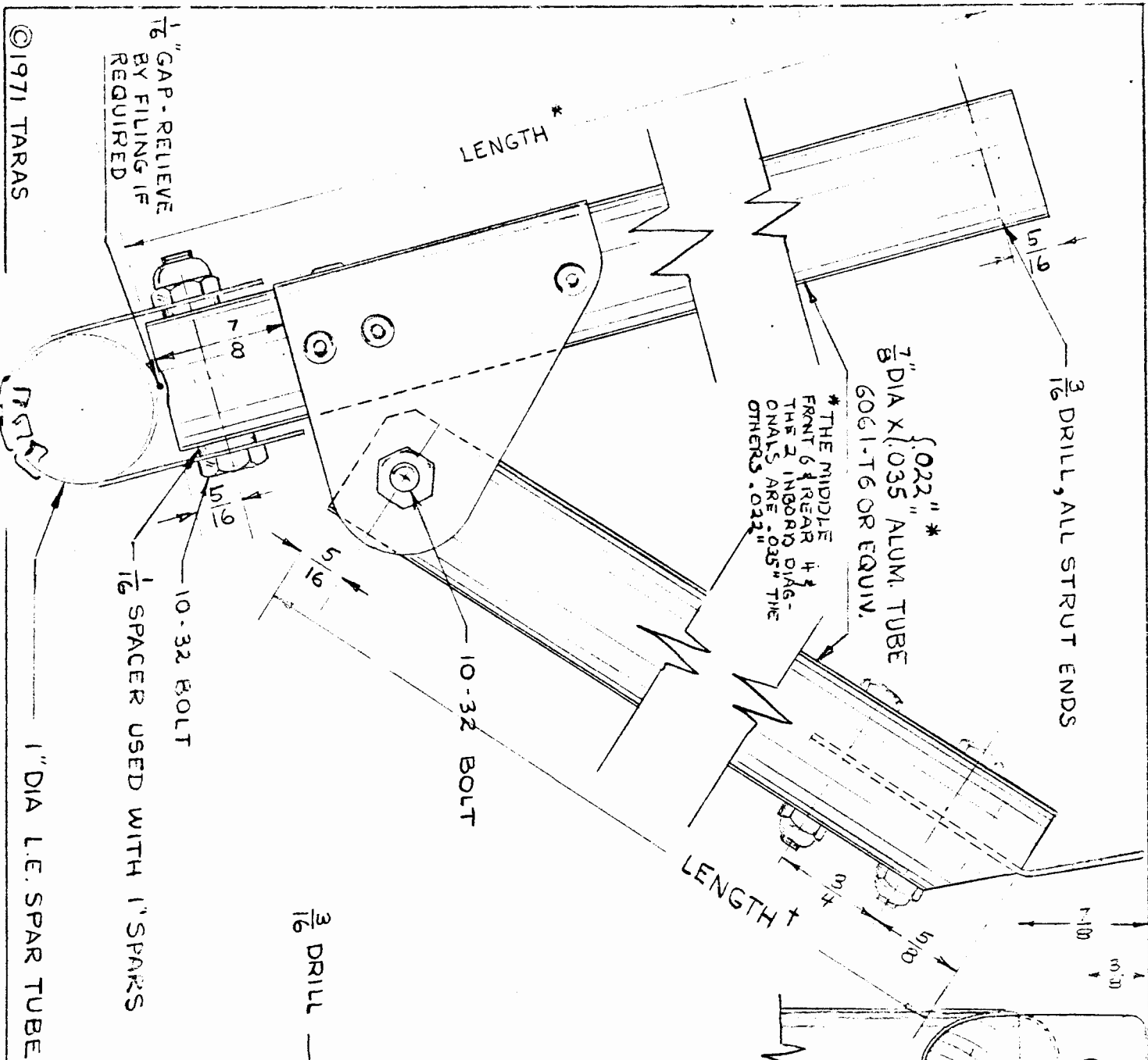

5 EXPOSED X .040" 4130 CHROME  
 DIAGONAL STRUTS OVER  
 ALL OTHER DIAGONALS  
 IN LOWER END SHOWN

POSITION	LENGTH*	NO. REQ'D
REAR COMP.	45"	8
FWD. COMP.	46 $\frac{1}{2}$ "	8

† DIAGONAL STRUTS SHOULD BE MEASURED AND CUT AT ASSEMBLY AND RIGGING. REFERENCE DIMENSION FOR GAP AND STAGGER SHOWN FOR INBOARD STRUT ASS'Y IN ①

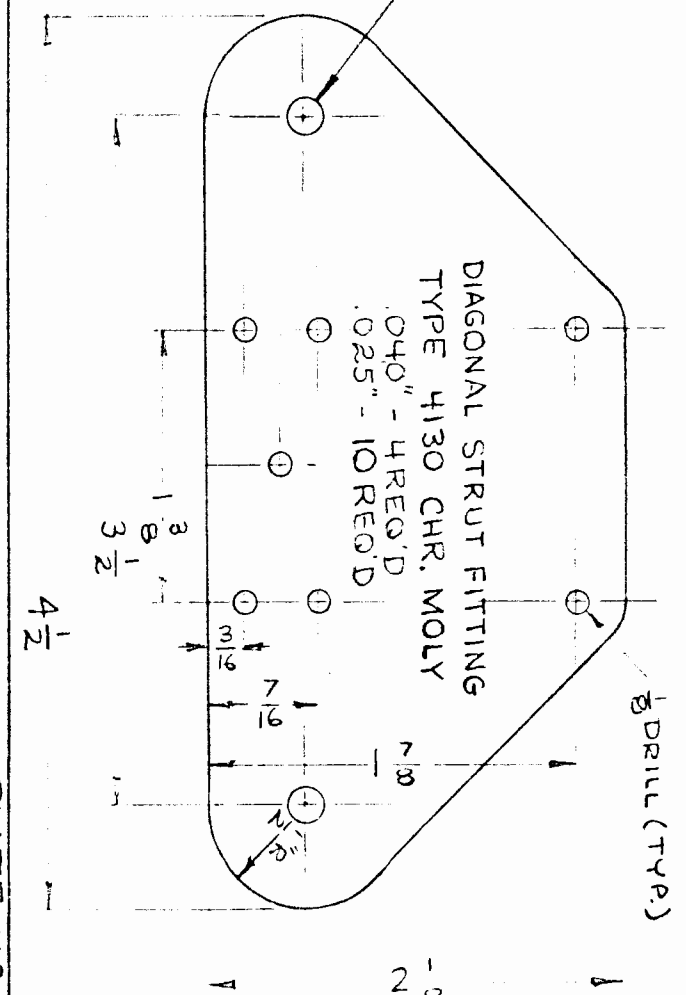

# POLYETHYLENE COVERING

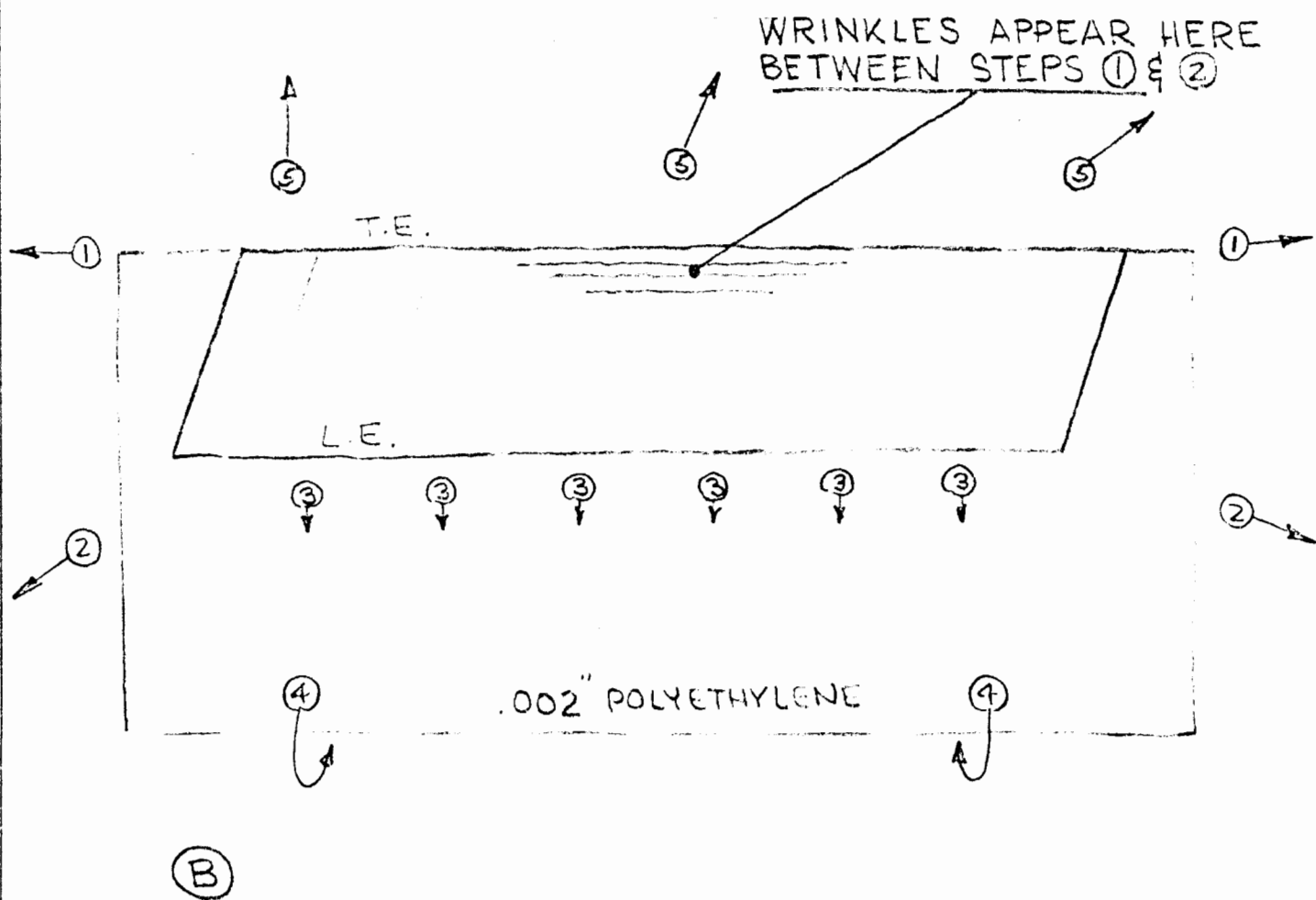
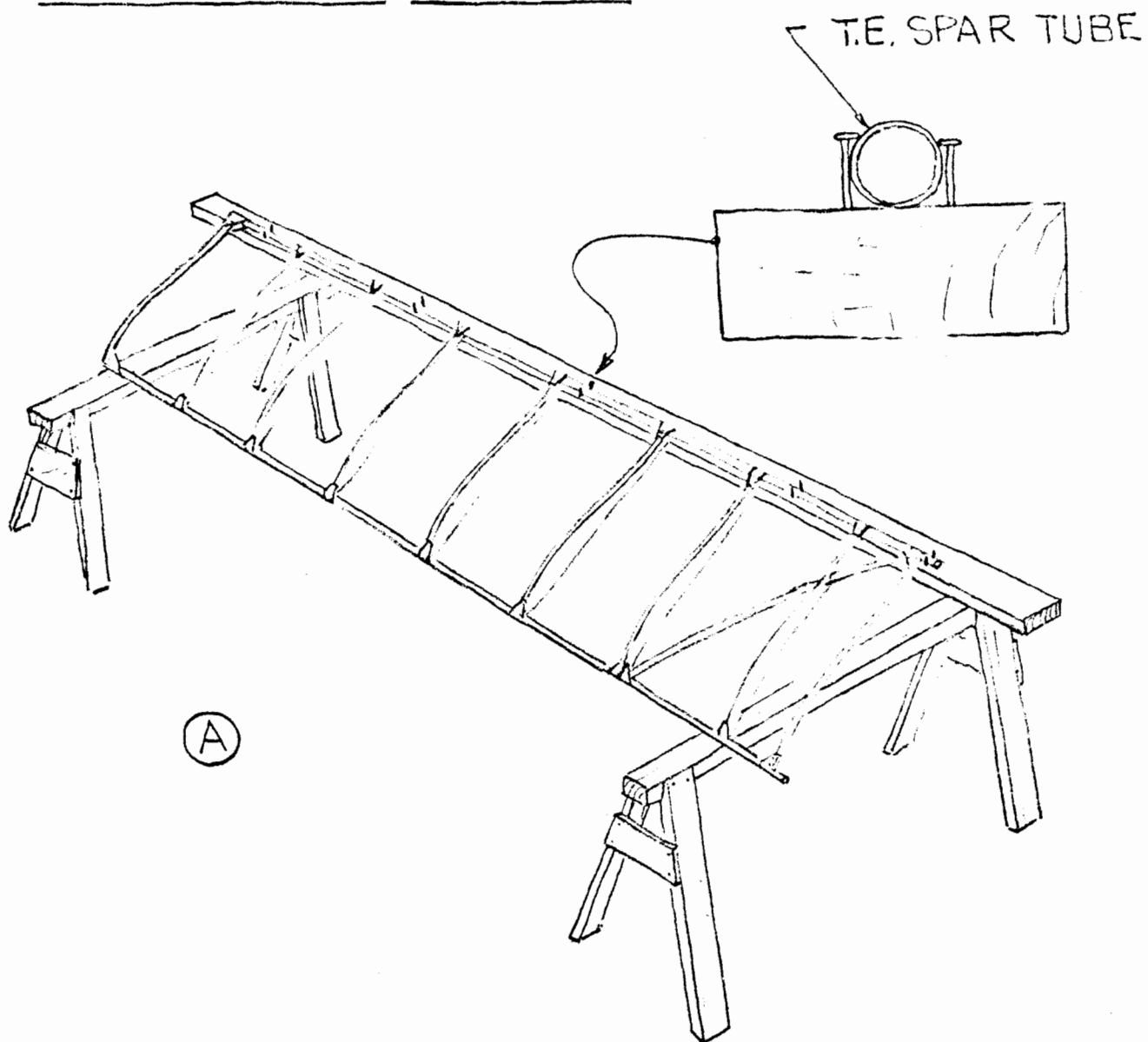

EXPLODED VIEW OF LOWER END  
RUDDER AIRPUT TUBE & BEARING

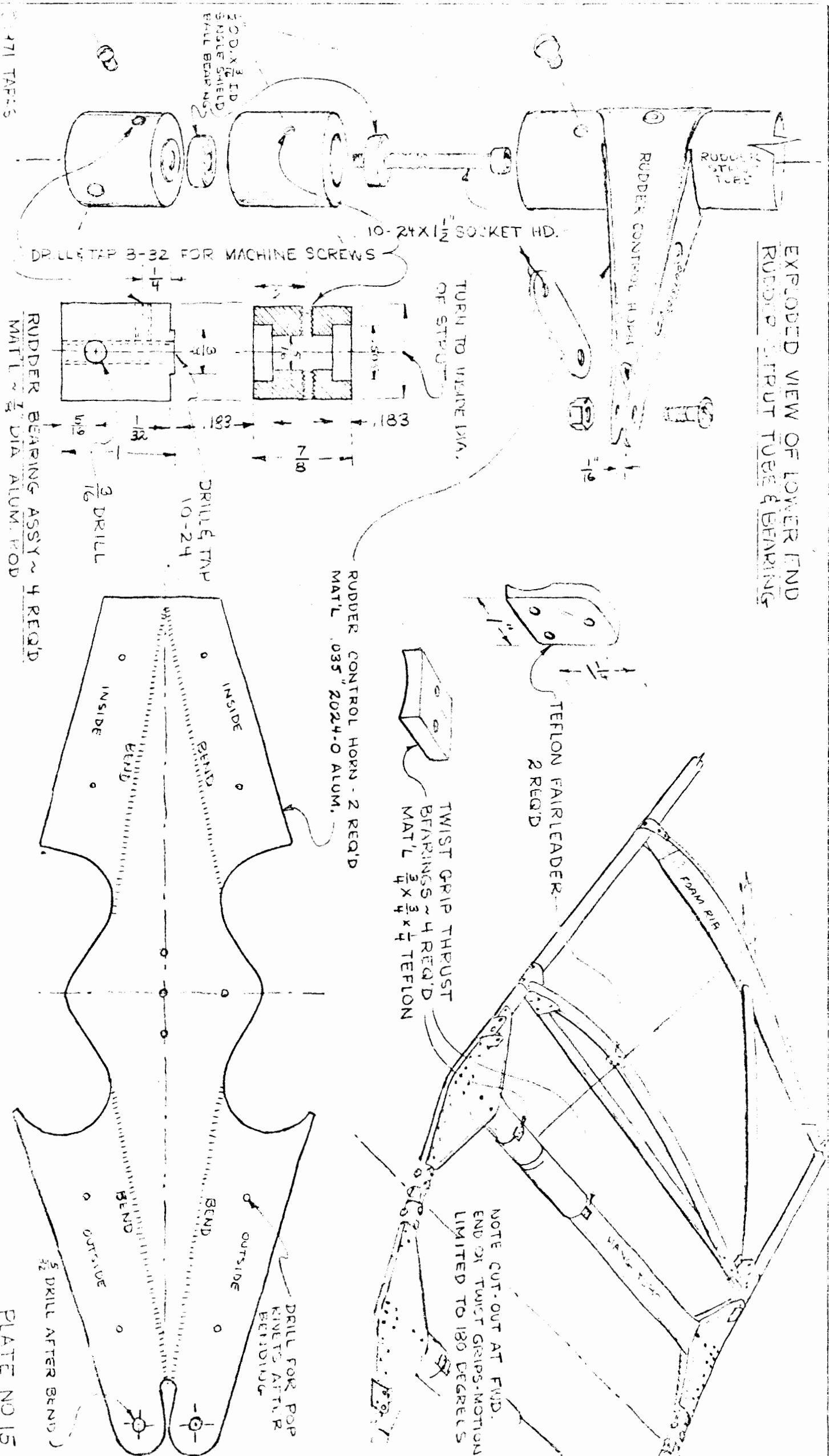

2-471 TAPES

MAT'L  $\frac{1}{4}$ " HARD Balsa ~ 3 COMPLETE, 2 PARTIAL UNITS REQ'D PER RUDDER.

$1\frac{1}{2}$ " SPRUCE STRIP 30" LONG

13"

3"

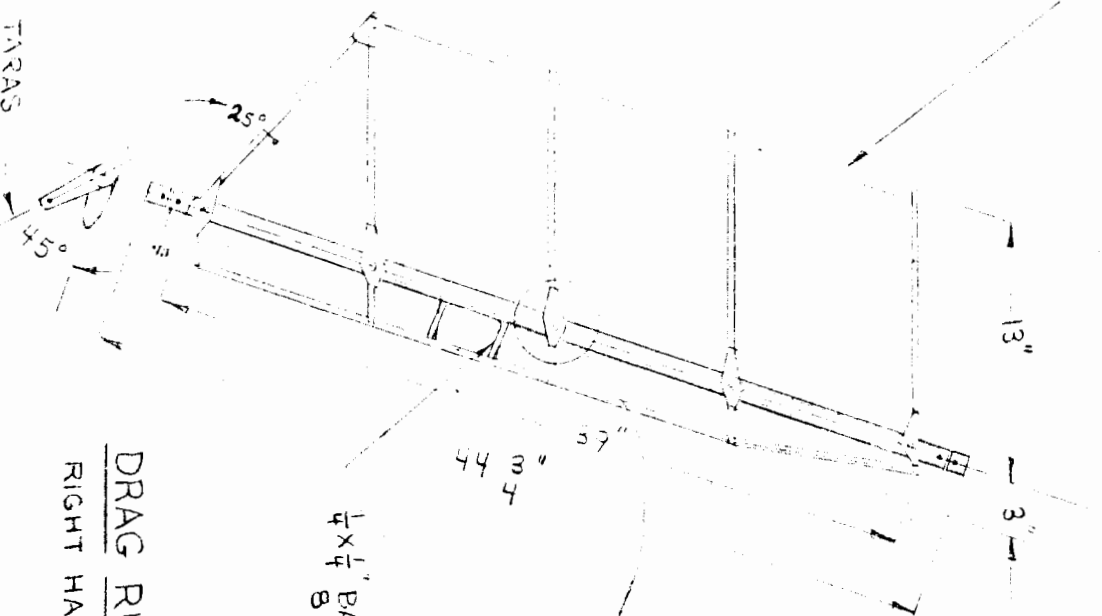

$\frac{1}{4} \times \frac{1}{4}$ " Balsa Stiffeners  
8 REQ'D PER RUDDER

$1\frac{1}{8}$ " PLYWOOD GUSSETS-6 PCS  
 $\frac{3}{82}$  REQ'D AS SHOWN, 4 SPEC'L  
PCS REQ'D FOR END RIBS.  
PER RUDDER UNIT.

REAR PORTION OF RUDDER RIB

FRONT PORTION OF RUDDER RIB

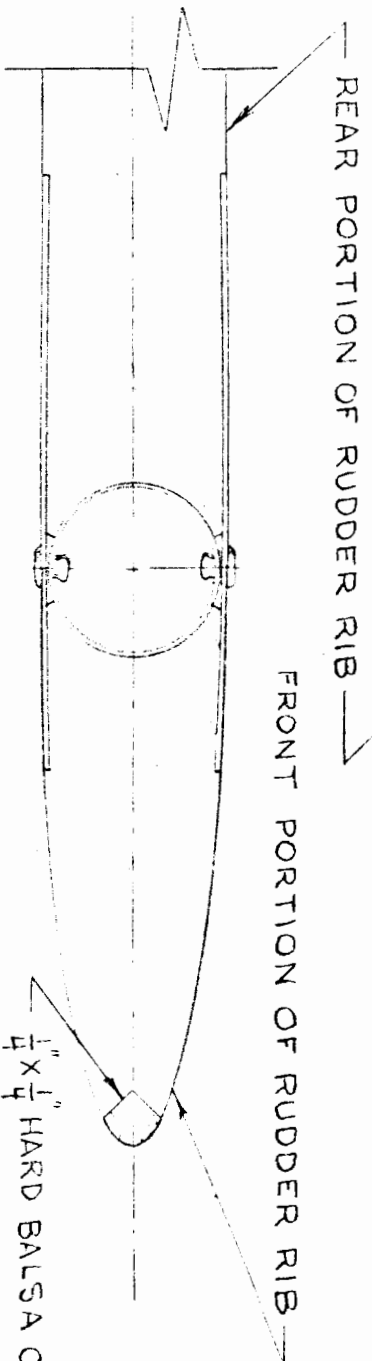

$\frac{1}{4} \times \frac{1}{4}$ " HARD Balsa OR SPRUCE

$\frac{7}{8}$ " DIA. X .022" WALL STRUT TUBE  
(REFER TO PLATE )

GUSSETS ARE GLUED  
TO Balsa, POP-  
RIVETED TO TUBE

DRAG RUDDER DETAILS

RIGHT HAND RUDDER SHOWN